

TAG RACING INTERNATIONAL

Manufacturer Address

Engine #

Manufacturer	
Make	
Model	
Inlet type	
Number of pages	

PICTURE OF ENGINE

(insert picture of front/left here)

(insert picture of back/right here)

Signature and Stamp

--	--

Importer	
----------	--



TECHNICAL INFORMATION

A CHARACTERISTICS		
	Measurement	Tolerances
Volume of cylinder		
Original bore		
Theoretical maximum bore		
Stroke		
Cooling system		
Number of carburation systems		
Number of transfer ports / ducts, cylinder / sump		
Number of exhaust ports / ducts		
Shape of the combustion chamber		
Length between axes of the connecting rod		
Minimum weight of connecting rod		
Volume of combustion chamber		
Type of bearings and size	<i>(example) 6205 type</i> Big End of Con. Rod Bearing = 18 X 24 X 15 Little End of Con. Rod Bearing = 14 X 18 X 17.5 Crankshaft Bearing = 25 X 52 X 15	

B OPENING ANGLES		
Exhaust		
Of exhaust ports / ducts		

C LIST OF ACCESSORIES INCLUDED	
<i>(List accessories as shown below)</i>	<i>Centrifugal clutch</i>
<i>Carburetor with butterfly ? 24</i>	
<i>Generator for battery charging</i>	
<i>Electric starter</i>	
<i>Exhaust with flex</i>	

D MATERIAL	
Cylinder	
Connecting rod	
Crankshaft	
Head	
Liner	
Crankcase	
Piston	
Piston Ring	



DRAWING OF THE CYLINDER DEVELOPMENT

(Insert drawing here)

Chord reading	
B	
C1=C2	
C3	
Angular reading by inserting a 0.2mm gauge	
E	
F	
G	

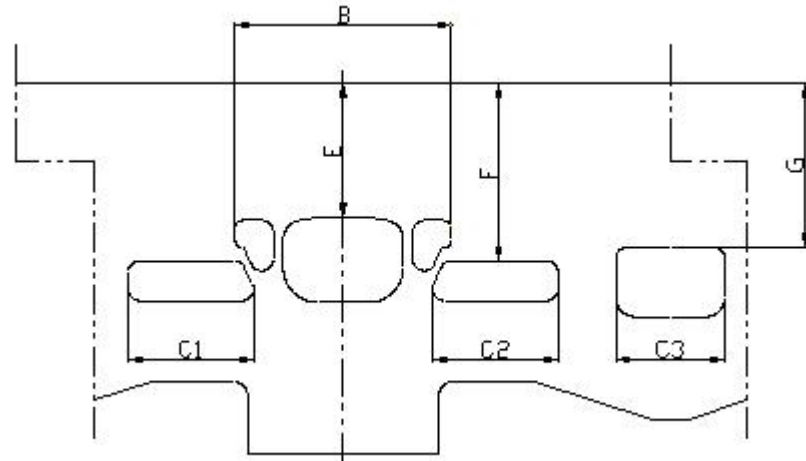

DRAWING OF THE CYLINDER BASE

(Insert drawing here)

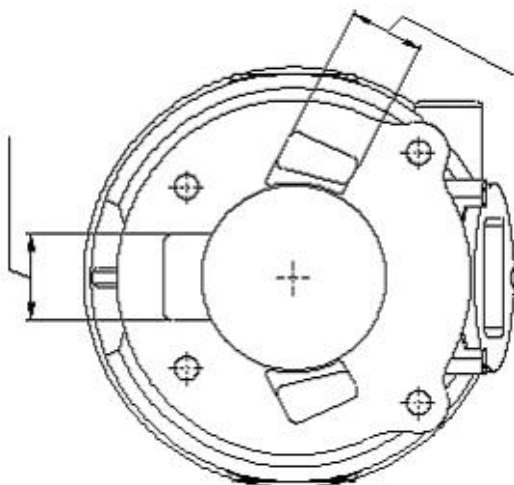

CYLINDER SECTION VIEW

(Insert drawing here)

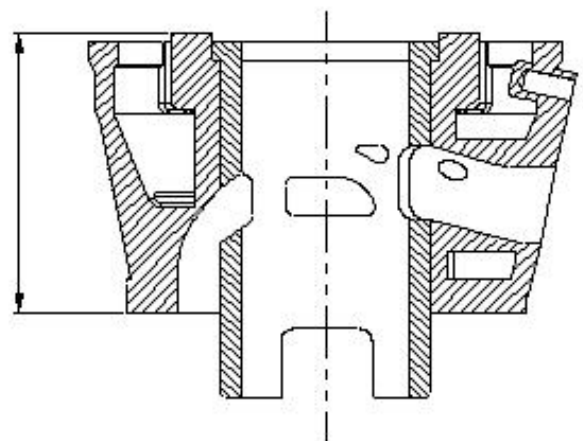



DRAWING OF THE CYLINDER HEAD AND THE COMBUSTION CHAMBER

(Insert drawing here)

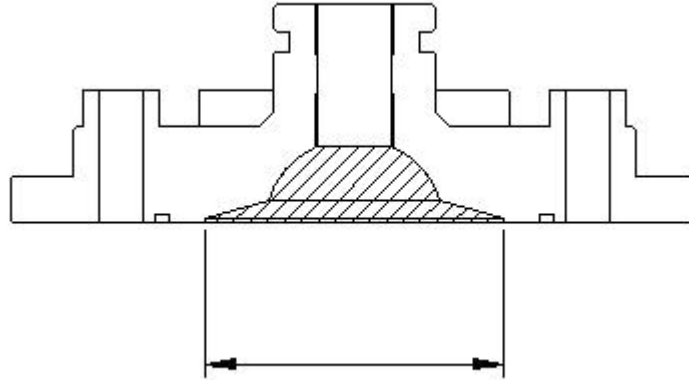

Combustion chamber volume = c.c. minimum

DRAWING OF THE CRANKSHAFT

(Insert drawing here)

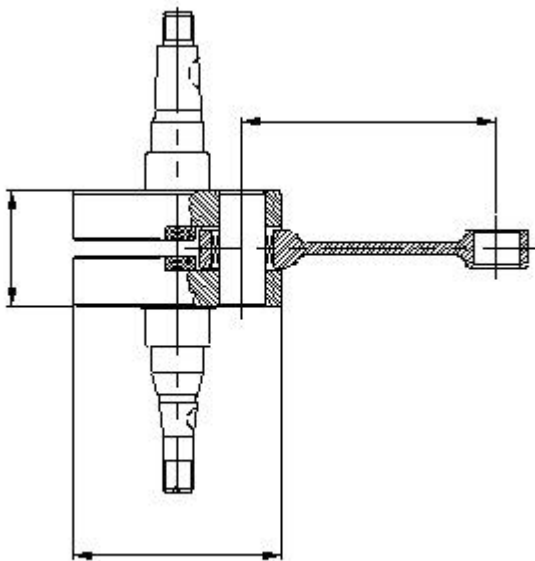

Complete weight = Tolerance= ±

DRAWING OF THE INSIDE OF SUMP

(Insert drawing here)

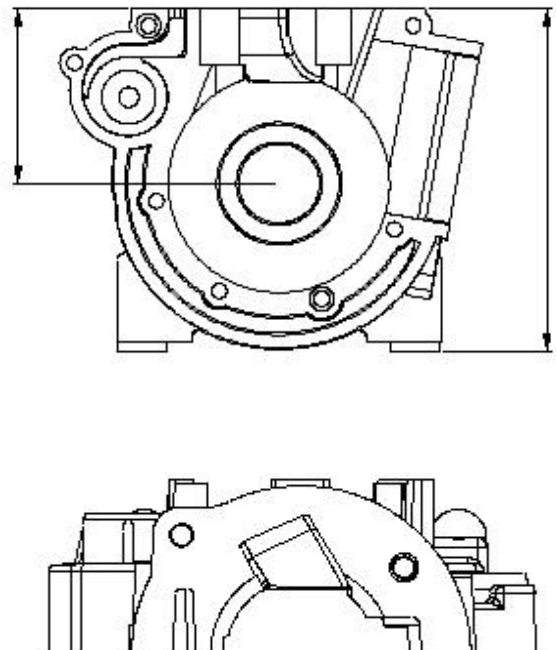



IGNITION	
Manufacturer	
Model Number	
Rotation	
Description	
PHOTO OF IGNITION	PHOTO OF COIL
<i>(insert photo of inside here)</i>	<i>(Insert photo here)</i>
<i>(insert photo of outside here)</i>	



CARBURETOR DIMENSION

(Insert drawing here)

Item	Measure	Tolerance
A		
B		
C		
D		
E		
F		

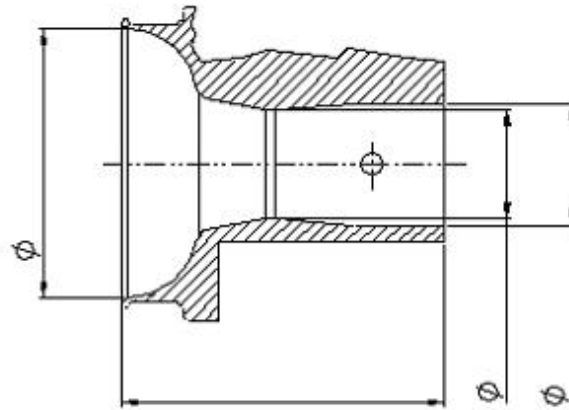

PISTON

(Insert drawing here)

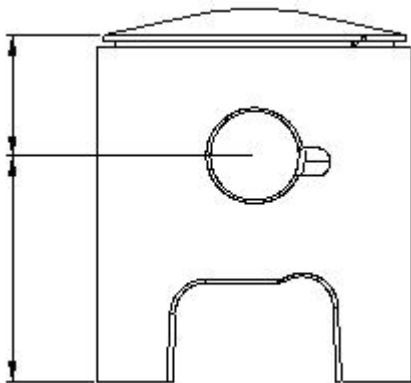

Weight=

Tolerance= ±

CONNECTING ROD

(Insert drawing here)

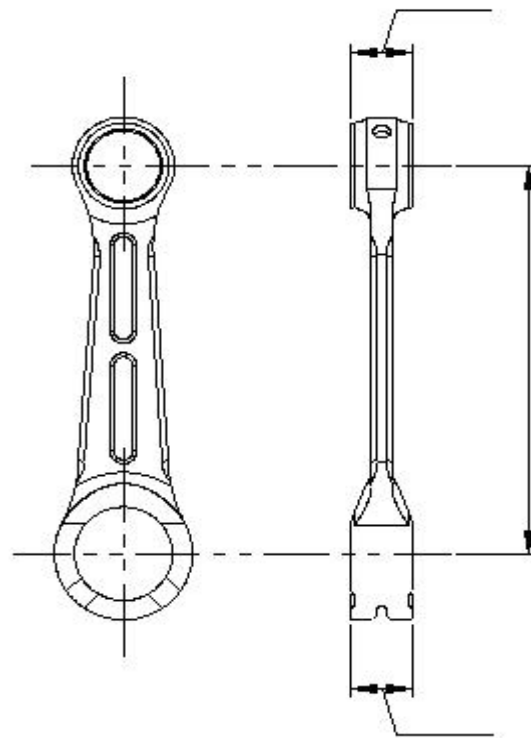

Weight=

Tolerance= ±



DRAWING OF THE SILENCER AND IT'S COMPONENTS

(Insert drawing here)

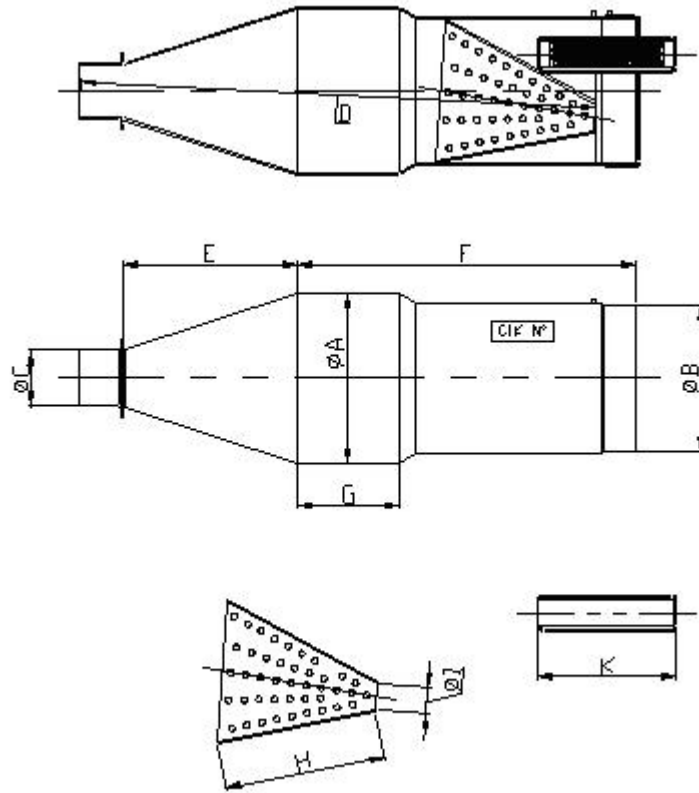

The end parts of the silencer must have two soldered pairs of lugs (one pair at the top and one pair at the bottom) to allow for fixing of seals by the Organizer so that the silencer may be opened during the competition

Measurements:

- A:
- B:
- C:
- D:
- E:
- F:
- G:
- H:
- I:
- J:
- K:



DRAWING OF THE SILENCER

(Insert drawing here)

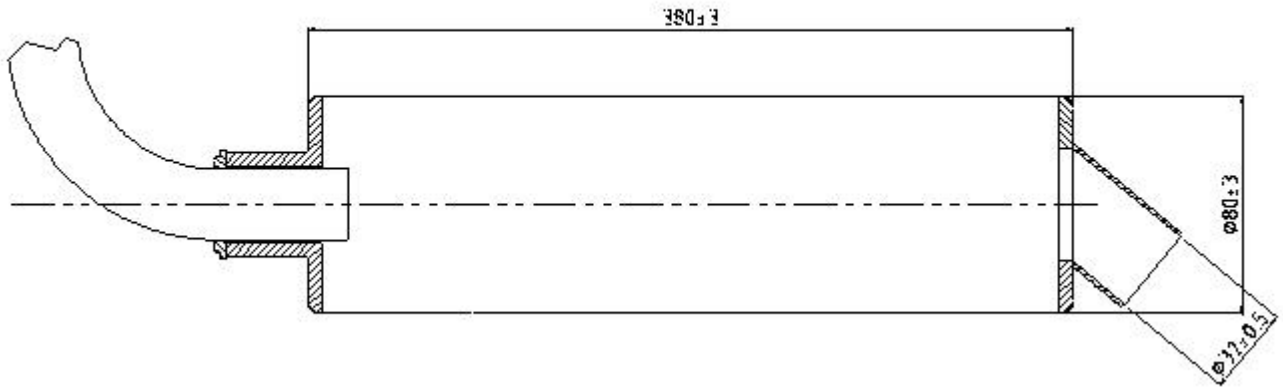

DRAWING OF THE CLUTCH

(Insert drawing of clutch used)

Item	Weight	Tolerance
A		
B		
C		

